

Modulating Retroreflector Implementation of MIL-STD-1553 Protocol with Free-Space Optics

Peter G. Goetz, W. S. Rabinovich, Timothy J. Meehan, D. S. Katzer,
Steven C. Binari, Eric E. Funk, and G. Charmaine Gilbreath
Naval Research Laboratory, Code 5650, 4555 Overlook Ave. SW, Washington, DC 20375
202-404-8208
goetz@nrl.navy.mil

Rita Mahon
Titan/Jaycor, 1410 Spring Hill Road, McLean, VA 22102

Lee Swingen
SFA, Inc., 9315 Largo Drive West, Suite 200, Largo, MD 20774

John Rende, Eugene Waluschka, Gary Lepore, and Anthony Phan
NASA Goddard Space Flight Center, Greenbelt, MD

Abstract—A modulating retroreflector (MRR) is used for a free-space optics (FSO) implementation of the MIL-STD-1553 protocol. A multiple quantum well (MQW) *p-i-n* structure is used for a single device that acts both as a modulator for transmitting data and as a photodiode for receiving data. A master node and two slave nodes with cat’s eye retroreflectors were designed using COTS optics. Two-way communication using the 1553 protocol is demonstrated at a separation of 3 meters, using widely available 980 nm pump lasers. The link was closed using only 15 mW of laser light. We have also demonstrated a coherent receiver to increase sensitivity and quadrature amplitude modulation (QAM) to enhance the data rate of a bandwidth-limited MRR.

connections once the spacecraft has been launched is quite difficult. The nature of the serial bus is also limiting because only one instrument can talk at a time limiting the aggregate data rate of the network.

The object of this work is to develop the components for a new type of spacecraft data network that utilizes free space optical data transfer. This free space optical network will allow the elimination of long wiring harnesses, enable point-to-point data connections, allow new data nodes to be added to a spacecraft after launch with relative ease, be immune to RF interference and allow data networks to easily extend outside of the spacecraft or to parts of distributed spacecrafts. In addition, the network will not require the very accurate alignment tolerances between nodes that are generally required by free space optics.

TABLE OF CONTENTS

1. INTRODUCTION	1
2. BACKGROUND	1
3. A 1553 CAT’S EYE DATA LINK ...	5
4. FUTURE DIRECTIONS	7
5. CONCLUSIONS	8
6. ACKNOWLEDGEMENTS	9
REFERENCES	9

2. BACKGROUND

2.1 Optical data transfer

Optical data communications using fiber optic connections is rapidly becoming the standard method of data transfer, particularly when high bandwidth or RF interference issues are important. Free space optical data transfer is also commonly used for short range, relatively low data rate links between portable or handheld computers (IrDA) or, even more commonly, in a variety of remote controls for consumer devices such as televisions or cameras. These broad-beam free space interconnects generally link a single transmitter device to a single receiver device. In fact such an interconnect can in principle allow a device to communicate with several receiver nodes at once but not in a point-to-point fashion. As shown below in Figure 1, in such a link the transmitter sends the same signal to all nodes.

Broad beam free space interconnects generally have moderate data rates (less than 10 Mbps) because they use low power emitters such as LEDs and because they spread their light over such a large area that there are insufficient received photons to

1. INTRODUCTION

Data transfer on-board a spacecraft is typically done using wiring harnesses (where the wires may be copper for electrical signals or fiber optic for optical signals) using a serial protocol such as 1553 or 1773. This approach has several limitations. The wiring harnesses themselves are undesirable because of their mass and large moment of inertia. Also, having an astronaut repair or add new

Report Documentation Page

Form Approved
OMB No. 0704-0188

Public reporting burden for the collection of information is estimated to average 1 hour per response, including the time for reviewing instructions, searching existing data sources, gathering and maintaining the data needed, and completing and reviewing the collection of information. Send comments regarding this burden estimate or any other aspect of this collection of information, including suggestions for reducing this burden, to Washington Headquarters Services, Directorate for Information Operations and Reports, 1215 Jefferson Davis Highway, Suite 1204, Arlington VA 22202-4302. Respondents should be aware that notwithstanding any other provision of law, no person shall be subject to a penalty for failing to comply with a collection of information if it does not display a currently valid OMB control number.

1. REPORT DATE 2003		2. REPORT TYPE		3. DATES COVERED 00-00-2003 to 00-00-2003	
4. TITLE AND SUBTITLE Modulating Retroreflector Implementation of MIL-STD-1553 Protocol with Free-Space Optics				5a. CONTRACT NUMBER	
				5b. GRANT NUMBER	
				5c. PROGRAM ELEMENT NUMBER	
6. AUTHOR(S)				5d. PROJECT NUMBER	
				5e. TASK NUMBER	
				5f. WORK UNIT NUMBER	
7. PERFORMING ORGANIZATION NAME(S) AND ADDRESS(ES) Naval Research Laboratory, Code 5650, 4555 Overlook Avenue, SW, Washington, DC, 20375				8. PERFORMING ORGANIZATION REPORT NUMBER	
9. SPONSORING/MONITORING AGENCY NAME(S) AND ADDRESS(ES)				10. SPONSOR/MONITOR'S ACRONYM(S)	
				11. SPONSOR/MONITOR'S REPORT NUMBER(S)	
12. DISTRIBUTION/AVAILABILITY STATEMENT Approved for public release; distribution unlimited					
13. SUPPLEMENTARY NOTES The original document contains color images.					
14. ABSTRACT					
15. SUBJECT TERMS					
16. SECURITY CLASSIFICATION OF:			17. LIMITATION OF ABSTRACT	18. NUMBER OF PAGES 10	19a. NAME OF RESPONSIBLE PERSON
a. REPORT unclassified	b. ABSTRACT unclassified	c. THIS PAGE unclassified			

support a high-speed link. Nonetheless such links are attractive because they have low sensitivity to alignment. Indeed the simplest replacement for a 1553 bus on a spacecraft would be a set of broad beam free space links.

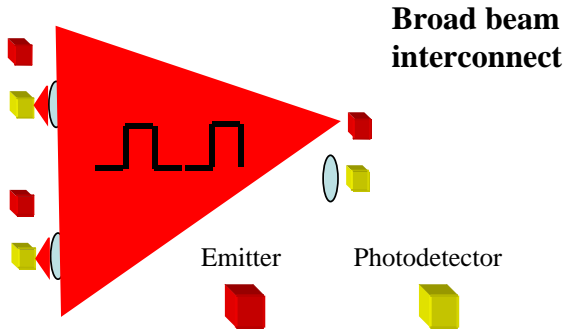

Figure 1: A broad beam free space optical interconnect

There are other applications in which high single channel data rate, point-to-point links are desired. These include data transfer between boards or even chips in a computer or from high data rate imaging sensors. For these applications another free space optical approach has been investigated intensively over the past decade [1]. This approach uses combinations of emitters, modulators and detectors arranged in planar arrays combined with micro-optics. In such a system, a transmitter in one plane is tightly imaged onto a receiver in a second plane, as shown below in Figure 2. Two forms of transmitters are used. In one case a single laser is split into multiple beams, each of which is modulated by a pixel in a modulator array. Alternatively the transmitter may be a small laser such as a VCSEL, which is directly modulated. These systems have the advantage of very high single channel data rates (hundreds of Mbps) because they are very efficient in their use of light. They are also true point-to-point systems with low cross talk between nodes. The net result is a potential of extremely high aggregate data rates exceeding terabits per second. The downside of this approach is extremely precise positional and angular alignment requirements of about 100 μm and 100 microradians (for a 1 meter long link) respectively. Such requirements are difficult to manufacture and maintain in equipment destined for use in the controlled environment of a terrestrial computer room and may be impossible to meet for spacecraft systems that must survive launch and work without maintenance for years [2].

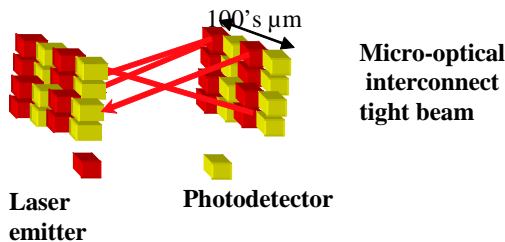

Figure 2: A micro-optical free space interconnect

2.2 Modulating retroreflectors

An alternative to the broad-beam or micro-optical free space optical interconnects is a new approach based on cat's eye modulating retroreflectors (CEMRR). A modulating retroreflector combines a passive optical retroreflector with an active electro-optic shutter. Because retroreflection is alignment insensitive, these kinds of links can combine some of the features of broad-beam and micro-optic links.

2.3 Multiple Quantum Well Modulators

Since 1998 the Naval Research Laboratory has investigated modulating retroreflectors based on semiconductor multiple quantum well (MQW) based electro-optic modulators [3]. These types of modulators have the advantage of having very high intrinsic switching times (greater than 10 GHz), and in practice are limited in their modulation rate only by RC time.

As shown in Figure 3, a MQW modulator is a PIN diode with multiple thin layers of alternating semiconductor alloys in the intrinsic region. These layers consist of a lower band-gap material, the well, and a higher bandgap material, the barrier.

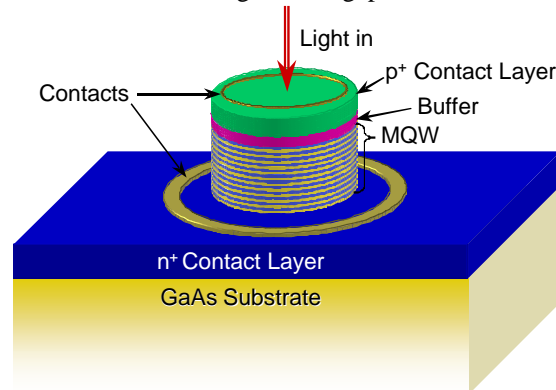

Figure 3: The layer structure of an MQW modulator

Because the semiconductor layers are very thin, the conduction and valence bands become quantized, and the exciton absorption feature at the band-edge becomes narrower in linewidth and enhanced in absorption. The center wavelength of the exciton is determined by the composition of the well material as well as the width of the well. When a reverse bias is applied across the MQW, the electric field changes the quantum well potential, shifting the exciton feature to the red and reducing the magnitude of the absorption. Thus a varying voltage on the quantum well is converted into a varying optical absorption over about a 10 nm bandwidth, as shown in Figure 4.

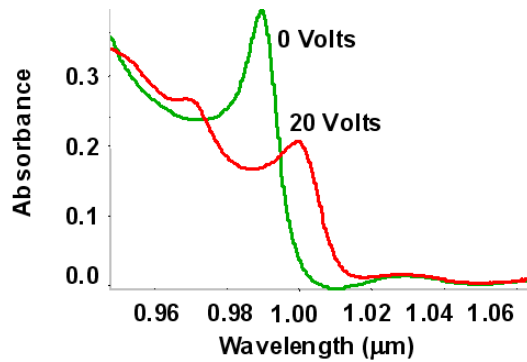

Figure 4: The band-edge optical absorption of a MQW for 0 and 20 V reverse bias

This sort of modulator is attractive for modulating retroreflector applications because it can have a large area, and its modulation characteristics are essentially free of angular dependence. Using InGaAs/AlGaAs MQW structures grown on GaAs substrates, operating wavelengths between 0.8-1.06 μm can be accessed [4]. Using InGaAs/InAlAs MQW structures grown on InP, the wavelength region around 1.55 μm can be accessed.

2.4 Cat's eye modulating retroreflectors

In almost all applications of modulating retroreflectors considered to date, the platform carrying the MRR is asymmetric with the platform carrying the interrogator. Generally the interrogator platform can handle more weight and has more available power, so it can carry a pointed laser interrogator. The situation for on-board data transfer is quite different since each data node is a peer of the other nodes. None of the nodes can use active pointing to maintain a link in the presence of environmental perturbations. The challenge then is to make use of the retroreflection characteristics of an MRR to relieve pointing requirements on *both* ends of the link. We can do this by combining the MRR concept with the broad beam free space interconnects described earlier. Such a system allows point-to-point interconnects because no information is carried on the broad angle beam, only on the narrow divergence retroreflected beams; thus there is low cross-talk.

To implement such a system we examined the use of a different form of MRR using a cat's eye retroreflector. There is no one form for a cat's eye retroreflector, but they generally combine lenses and mirrors and incorporate an optical focus. A spherical cat's eye is shown below in Figure 5.



Figure 5: A spherical cat's eye retroreflector

We can use the fact that a cat's eye retroreflector has an optical focus whose position varies based on the incidence angle of light upon the cat's eye to channelize the return from multiple nodes and allow point to point links. We have designed an alternative form of cat's eye retroreflector that uses a telecentric lens pair, a flat mirror and a MQW modulator/receiver array inserted into the optical system in front of the mirror. This cat's eye modulating retroreflector (CEMRR) node also has an emitter, a fiber coupled laser diode reflected from a dot coupler placed in front of the cat's eye aperture. A diagram of a CEMRR node is shown below in Figure 6.

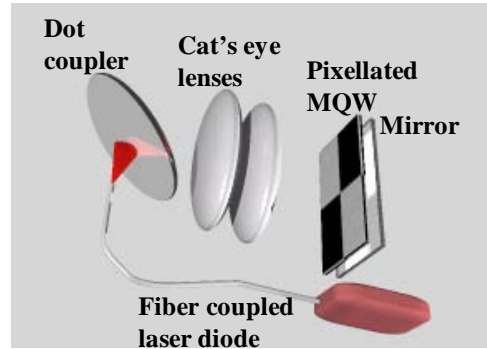

Figure 6: A cat's eye modulating retroreflector transmitter/receiver node

A set of CEMRR nodes can exchange data in a point-to-point fashion by interrogating each other with broad cw (continuous wave, *i.e.* unmodulated) laser beams and receiving narrow divergence retroreflected signal containing data streams.

Below, in

Figure 7, a typical set of CEMRR nodes is shown. In the following description, the node on the right will act as an interrogator, while the nodes on the left will act as transmitters.

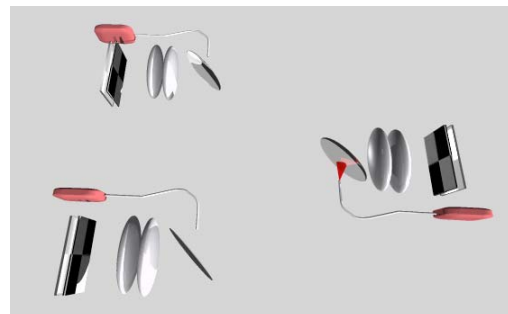

Figure 7: A set of cat's eye modulating retroreflector nodes

In operation, as shown in Figure 8, the interrogator node emits a broad cw laser beam that paints both of the transmitter nodes. This beam carries no information, so the fact that it intercepts two nodes causes no cross talk. Its broad angular divergence and large footprint ensures that the interrogation beam has little positional or angular sensitivity. As shown in Figure 9, the portion of the interrogation beam that intercepts

each interrogator node is focused by the lenses and passes through a pixel in the MQW array. The particular pixel that the light passes through depends on the relative spatial positions of the interrogator and transmitter. In a properly designed CEMRR system each pair of nodes will have a unique pixel associated with it. This is what allows point-to-point links.

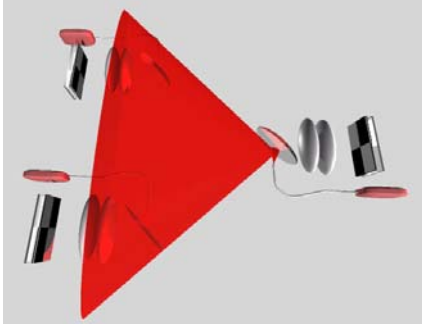

Figure 8: A cat's eye interrogator node paints two cat's eye transmitter nodes

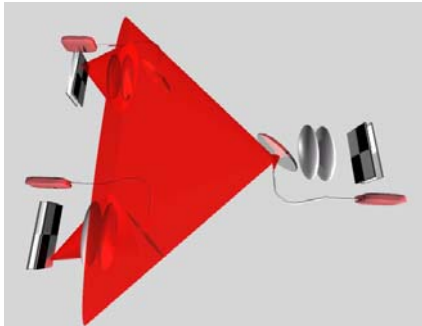

Figure 9: Interrogating beam focuses onto pixels in the transmitter nodes of a CEMRR system

The light passes through the transmitter node MQW pixel twice (once on entering and once after reflecting). The driver electronics modulates the pixel voltage, which in turn modulates the absorbance of the pixel. This amplitude modulates the incoming cw light with the signal. As shown in Figure 10, this light then retroreflects in a narrow divergence beam back to the interrogator.

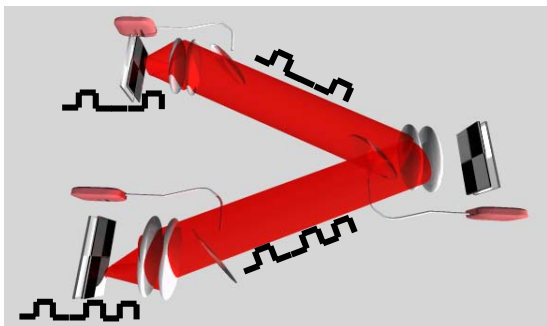

Figure 10: The transmitter nodes retroreflect their data back to the interrogator node

Finally the retroreflected beams intercept the lenses of the interrogator node where they focus onto the interrogator's

MQW array, again onto a particular pixel determined by the relative positions of the interrogator node and the transmitter node. In this case however, we bias the MQW with a constant voltage and detect the photocurrent produced by the retroreflected beam. Because an MQW is a PIN diode it can act as a photodetector. As shown in Figure 11, the retroreflected signals from each transmitter focus onto different interrogator MQW pixels.

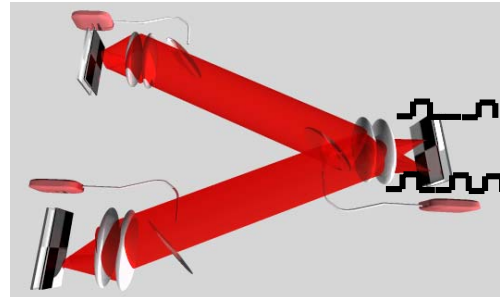

Figure 11: The retroreflected signals are detected by the interrogator

A system of CEMRRs has a variety of sensitivities to angular or positional misalignment. If the interrogator position shifts, the broad interrogating beam will shift with it, but as long as the interrogator shift is less than the footprint of the interrogating beam the link will be maintained. Similarly if the position of either of the transmitters shifts by less than the interrogating footprint, the link will be maintained. If the angle of the interrogator shifts, the position of the interrogating beam will shift, but if this angular shift is smaller than the angular width of the interrogating beam then the transmitter nodes will still be painted with the interrogating beam. If the angle of a transmitter node shifts it will have no effect on the link because the light is retroreflected, as long as the interrogator remains within the field of view of the transmitter's retroreflector (typically about 30 degrees).

A more subtle alignment sensitivity occurs upon retroreflection if the positions of any of the nodes shift. For shifts smaller than the interrogator footprint, retroreflection will still occur, but the focal positions on the MQW arrays in both the interrogator and the transmitters will shift. Because of the demagnification of the cat's eye lenses the focal plane shift is much smaller than the physical shift of the nodes. This shift can be handled in two possible ways. First, if the pixels are sufficiently large then these positional shifts will not move the focal spots off the proper pixel. For a typical system, a 1mm pixel would allow for 5 cm node shift. An alternative approach is to overfill the MQW array with more pixels than nodes. Then if a shift occurs pixels can be reassigned to different node pairs. An advantage of the second approach is the possibility of adding more nodes later on. This opens up the possibility of networks that can automatically add new physical point-to-point connections as new nodes are added.

The net result of the CEMRR system is one which combines some of the features of both broad beam and micro-optical free space interconnects. The system has the low alignment

sensitivity of the broad beam system but has the point-to-point connectivity of the micro-optical system. It is less efficient in its handling of light than the micro-optical system but more efficient than the broad beam system (because all the nodes that fall within the footprint of the interrogator beam have their own data channel).

3. A 1553 CAT'S EYE DATA LINK

To demonstrate the utility of a cat's eye modulating retroreflector we have been developing a free space optical 1553 bus using CEMRR nodes. The 1553 protocol is not optimal for using CEMRRs, but it is ubiquitous on spacecraft and so is a good first step towards more flexible architectures.

A cat's eye modulating retroreflector system requires an integrated set of optical, electronic and photonic components. The optical system must retroreflect light (though diffraction limited beam quality and accuracy is not needed for short-range links). It must also allow for the insertion of an MQW modulator/receiver array into the optical path. The MQW device must balance the requirements of optical modulation with photoresponse. It must also be robust enough to survive launch and operate in a spacecraft environment. The interface to the 1553 bus presents a set of challenges. The 1553 signal must be converted to the appropriate driving voltage for the MQW when the MQW is used as a modulator. When the MQW is used as a receiver, a DC bias must be put on the device, and the photocurrent must be amplified up to the point where it can be reinserted into the electrical 1553 bus. The logic and components must encompass these needs as well as at least simulate a peer-to-peer bus. In the subsections below we will describe our progress to date on these goals.

3.1. Optical Design

Unlike a typical cat's eye retroreflector, the optics in the CEMRR nodes must accommodate a planar MQW array. We approached this problem by using a 1 cm diameter telecentric lens with a planar, reflective MQW array in the focal plane. This arrangement retroreflects light over a 30-degree field of view with a retroreflected beam divergence of 1 milliradian (approximately 4 times the diffraction limit). The focal spot at the modulator plane is 140 μm in diameter.

In addition to the cat's eye optic, the CEMRR node must incorporate a laser to emit the broad interrogation beam. It is not necessary for each node to have its own laser. The light from a single laser diode can be divided and distributed using optical fiber to a number of closely spaced nodes acting as a sort of optical power supply. Because the interrogation beam will be precisely retroreflected, the interrogation beam should be centered on the cat's eye optic. We achieved this by using a laser diode coupled to a single mode fiber. The fiber was coupled to a lens, which was adjusted to diverge the beam

to a diameter of 15 cm at a distance of 3 meters from the node. A glass window with a 1 mm diameter mirror ("dot") of evaporated gold in its center was mounted directly in front of the cat's eye optic, and the light from the laser diode was reflected off the dot and towards the other nodes. Because the fiber was quite close to the gold dot, almost all of the light from the laser is coupled out into the interrogation beam. This is illustrated in Figure 8. Upon retroreflection, the return beam is approximately 1.5 cm in diameter so that the 1 mm dot obscures only a small part of the light entering the cat's eye lens. Figure 12 below shows a CEMRR node.

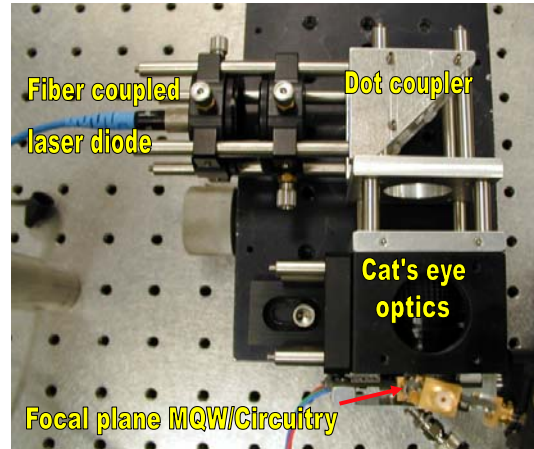

Figure 12: A cat's eye modulating retroreflector node

3.2 MQW Modulator/Receiver

A multiple quantum well structure consists of multiple thin layers of semiconductor alloys. The alloy with the lower energy band-gap is called the well, and the alloy with the higher energy- band-gap is called the barrier. The alloy composition and width of the well material determine the operating wavelength of the modulator.

The MQW devices for the CEMRR nodes must act as both optical modulators and photodetectors. This places some additional restrictions on the design of the MQW layers. In particular, to maintain good photodetector responsivity, the barriers must not be too thick, but if the barriers are too thin the optical modulation contrast will be low. We designed a MQW structures using a self-consistent transfer matrix code. The MQW was designed for operation at 980 nm and were grown via molecular beam epitaxy at NRL.

We chose 980 nm as the operating wavelength. 980 nm laser diodes are used to pump 1550 nm Erbium doped optical amplifiers (EDFAs) used by the telecommunications industry. The use of 980 nm diode lasers allows us to leverage the high investment by industry in making these lasers powerful and reliable.

A photolithography mask was created, and a set of 1 mm diameter MQW test structures was produced by metallization and wet chemical etching. The same wafer was later used to fabricate the 2x2 MQW arrays used in the CEMRR.

We evaluated the resulting device's DC photoresponse by placing the structure under a DC reverse bias, illuminating it with a calibrated tunable laser diode, and measuring the current. A dark current measurement was also taken. The subtraction of the two curves gives the DC photoresponse shown below in Figure 13.

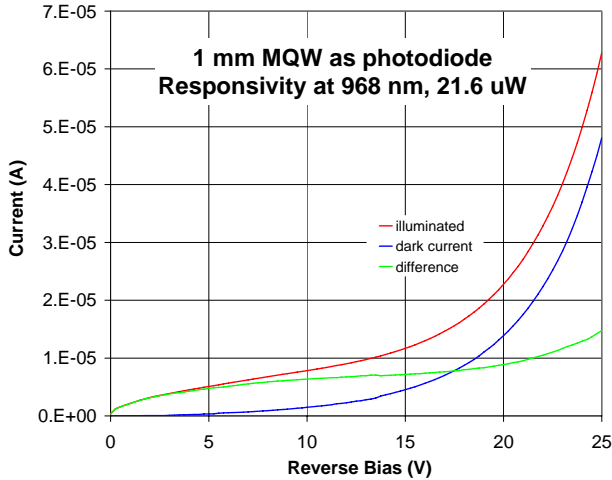

Figure 13: DC Photoresponse of 980 nm MQW structure

The responsivity, shown by the green curve, becomes relatively flat by about 8 V reverse bias at about 0.3 A/W. At biases above about 20 V the responsivity climbs again, perhaps due to avalanche gain.

The modulation contrast of the MQW was measured using a similar set-up to that used for measuring the photoresponse. In this case the light passing through the MQW was focused onto a silicon photodetector. A modulated bias was placed upon the structure and the resultant modulated optical signal was measured. The extinction ratio of the modulator was 0.6. Higher extinction ratios can be achieved with MQW modulators, but at the cost of photoresponse.

3.3 MQW Array

The geometry of the pixelated MQW array is determined by the optics of the cat's eye lens and the location of the

other nodes in the system. The focal spot moves 1 mm for a 2.5° change in incident angle upon the cat's eye. For a link length of 3 meters and a node separation of 10 cm, the pixel separation must be 800 μm. A 2 x 2 pixel photolithography mask, shown below in Figure 14, was used to process the MQW into a small array. The backside of the wafer was metalized to act as a reflector. The active area of each pixel measured 700 μm by 700 μm, with a 150 μm gap to minimize the possibility of optical cross-talk.

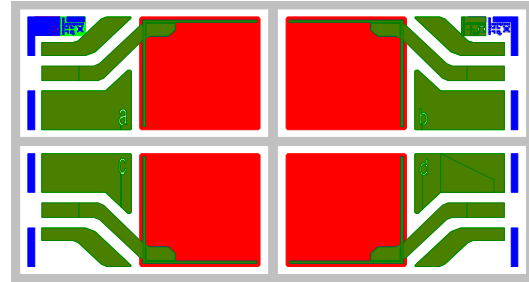

Figure 14: Cat's eye array photolithography mask

3.4 MQW Driver/Preamplifier Electronics

One of the unique aspects of our implementation of a two-way free-space optical link is that we are using the same device as both a modulator and as a photodiode. This requires merging modulator driver electronics and photodiode amplifier electronics in a novel way.

To operate as a transmitter in a 1553 network, driver electronics must take the incoming 1553 signal and convert it to produce the necessary modulation drive. When operating as a receiver, the electronics must amplify the photocurrent sufficiently to feed back into the 1553 network. We achieved this with the circuit shown in Figure 15. The device is operated in reverse bias for operation both as a modulator (MOD) and as a photodiode (PD). The driver (EL7212) provides a digital signal of 0/15V for modulation. Back-to-back diodes hold the p-side of the device nominally to ground during transmission. This is necessary because the very large currents (compared to the photocurrent) used to modulate the MQW saturate the preamplifier, preventing it from holding ground on the MQW side.

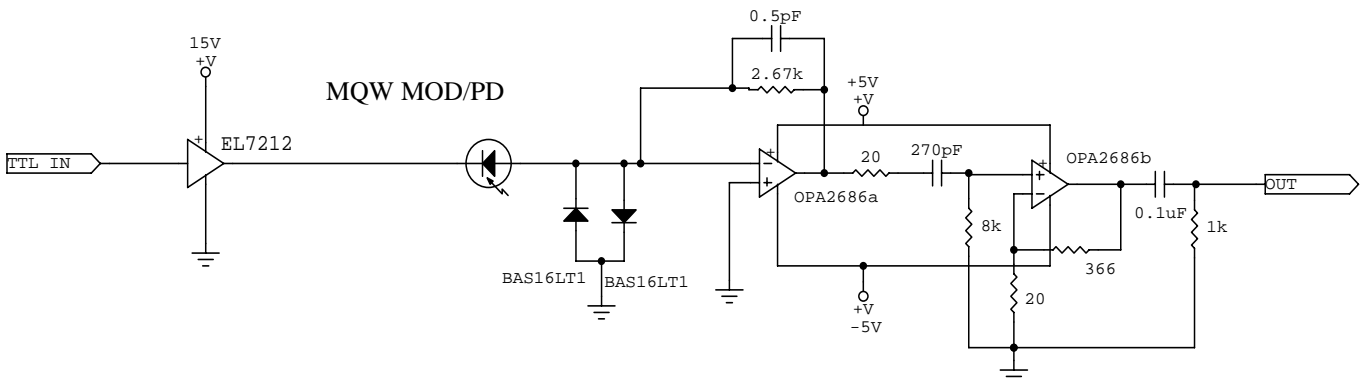

Figure 15: Block diagram for cat's eye focal plane electronics

In receiver mode, the EL7212 is simply held high at a constant 15V. This avoids problems with charge injection from analog switches or frequency response conflicts with a bias-T configuration.

3.5 Cat's eye link budget

Using 2 CEMRR nodes we measured a 2-meter cat's eye link using a 10 cm spot size at the interrogated node and 6 mW of optical transmit power. The SNR of the received signal was 50, sufficient for a raw bit error rate of 10^{-9} . The budget for this link is shown below:

Source	8 dBm
Geometric loss (interrogator to transmitter)	-20 dB
Transmitter cat's eye optical loss	-4 dB
MQW loss	-5 dB
MQW modulation contrast	-4 dB
Geometric loss (transmitter to interrogator)	-3 dB
Interrogator cat's eye optical loss	-2 dB
Total	-30 dBm
Receiver sensitivity	-30 dBm

3.6 1553 Logic and Interface

A 4-node 1553 bus was set up with one bus controller (BC) and three remote terminals (RT). The BC was connected to two of the RTs with free-space links, while it was connected to the third with a traditional cable. The free-space links were 3-meters in length. Signals passed normally, and the free space optical portion of the bus was transparent to the instruments. The physical arrangement of two FSO nodes is shown below in Figure 16, and a typical trace from the data stream in Figure 17.

The BC was configured to send commands to each of the RTs separately, and then query them individually for data.

In operation the CEMRR nodes could be moved several centimeters and twisted by several degrees without disturbing the link. Thus these sorts of free-space links should be quite robust against vibrations misalignment. They are also relatively easy to set-up since alignment tolerances are loose.

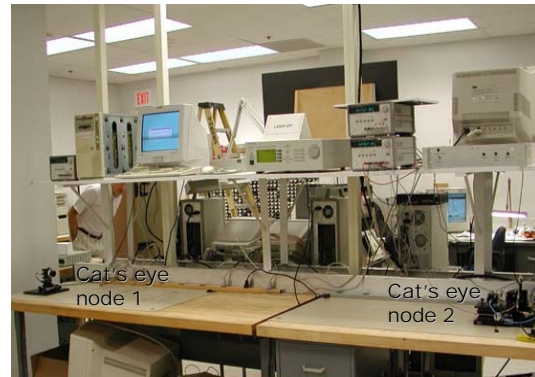

Figure 16: Laboratory set-up for the free space 1553 bus

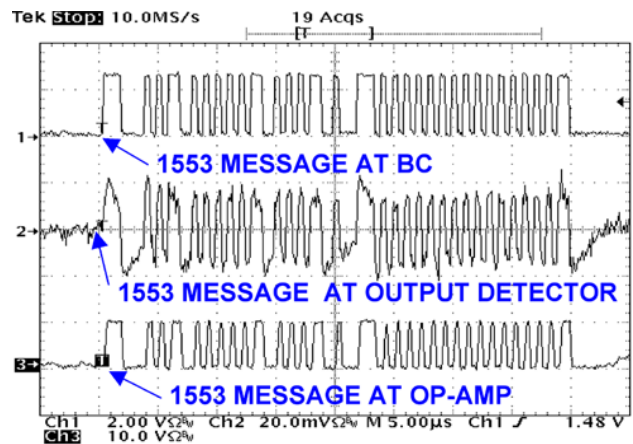

Figure 17: 1553 data trace transmitted over the free space optical bus. Trace 1 is the message sent by the bus controller (BC), trace 2 is between the TIA and the voltage amplifier, and trace 3 is at the input to the 1553 instrument

4. FUTURE DIRECTIONS

4.1 Coherent MRR

One important technique we have demonstrated is the use of a coherent receiver to increase sensitivity. As with virtually any FSO system, increased receiver sensitivity would benefit the system in many ways. Increased receiver sensitivity could decrease the laser power required, or it could be used to enable the interrogating laser beam to be spread out more, thus increasing the areal coverage of a single laser. Additionally, coherent techniques potentially allow FSO links between spacecraft.

One unusual aspect of a MRR system is that the interrogating laser and the receiver are collocated. This aspect makes the use of a coherent receiver particularly attractive. By splitting off a portion of the interrogating laser, a local oscillator (LO) is made available to mix with the returning signal beam. This is accomplished at very low cost without the need for an additional laser or an optical phase-locked loop. Design changes are only required in the interrogator, so increased ranges can be realized without changes to the transmit circuitry.

The detection of the optical \vec{E} -field in a coherent system (as opposed to intensity in a direct detection system) changes the fundamental range limitation of a MRR system. A significant additional benefit for free-space optical (FSO) communication is that coherent reception is quite insensitive to interference from background light.

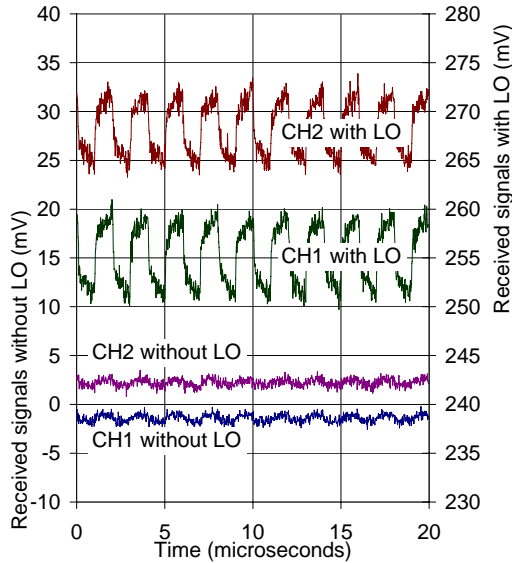

Figure 18: 500 kHz signals shown with and without LO signal, 50 mV full scale

We have demonstrated a homodyne coherent modulating retroreflector system. A comparison of the signals with and without coherent amplification is shown with 50 mV full scale in Figure 18. As can be clearly seen, signal to noise ratio improved greatly. This system incorporated a phase-diversity receiver in order to mitigate the effects of the atmosphere on phase. The lack of atmosphere in space-borne systems would eliminate the need for phase diversity, reducing the number of optical components and simplifying the data processing.

4.2 Vector modulation formats/QAM

While device performance may limit our modulation rate to several MHz, the data can be increased well beyond this rate by use of more spectrally efficient modulation formats such as m -ary quadrature amplitude modulation (m -QAM). Many cable and wireless modems now use this format.

While conventional digital RZ and NRZ modulation formats use a two-state (on/off) symbol, the m -QAM format encodes m unique phase and amplitude states onto an RF carrier. Since m -QAM generally requires higher signal to noise ratio and much better linearity than the RZ and NRZ formats, QAM links are often designed to tolerate uncorrected bit error rates as high as 10^{-4} . Forward error correction, typically Reed-Solomon, then provides correction to $<10^{-9}$ levels.

Initially we have experimented by sending a 256-QAM modulated 9 MHz carrier through our modulating retroreflector (MRR) in the laboratory. This allowed us to achieve a notable throughput of 40 Mb/s at a symbol rate of only 5 MHz (8 bits/symbol). This rate was limited by the bandwidth of the vector signal generator and analyzer. The received signal constellation and associated statistics are shown in Figure 19.

Impairment to the modulation from noise and distortion is generally quantified by measurement of the rms error vector magnitude (EVM). The error vector represents the phase and amplitude difference between the ideal and actual received signals. An EVM of 2.4% rms was measured in our 256-QAM experiment with decision feedback equalization. This performance level indicates that system noise and nonlinear distortion in the MRR is sufficiently small to support this data rate with conventional forward error correction. One could envision extending this approach to either higher symbol rates or multiple frequency division multiplexed channels for even higher throughputs.

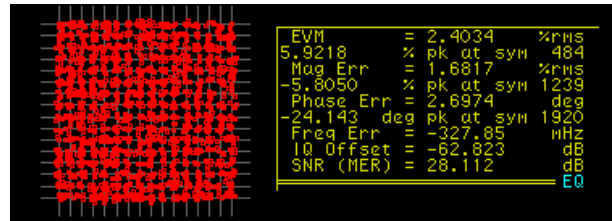

Figure 19: 256 QAM (8 bits/symbol) as transmitted through our modulating retroreflector. X- and y-axes represent sine and cosine components of the 9 MHz carrier.

4.3 Diffraction-Limited Cat's Eye

Another method to extend the range of the free-space optics is to make the retroreflector diffraction-limited. We have designed and fabricated a 980 nm diffraction-limited cat's eye retroreflector. It is a 5 element design with one aspheric component. It is an $f/2$ system with a 1.6 cm aperture and a 30 degree field of view (FOV). It was simulated with Zemax software, and has been evaluated to accurately retroreflect with an aberration free wavefront over the full FOV.

5. CONCLUSIONS

Free space optical data transmission offers many advantages for data networks on-board spacecraft. The CEMRR approach essentially trades efficient use of laser power for reduced alignment sensitivity. Since lasers diodes are excellent converters of electrical power into light (generally exceeding 50% efficiency) this is often a good bargain.

We implemented a 1553 bus using CEMRR nodes because this protocol is the most widely used onboard spacecraft. It is however a poor choice of protocol for making the most of what the cat's eye approach has to offer. This is because the CEMRR nodes naturally fit a self-configuring point-to-point network rather than a serial network. For our current

hardware each node is capable of simultaneously supporting a 1 Mbps link to every other node. Thus for example, a 10-node system could support an aggregate data rate of 100 Mbps. However, since the 1553 protocol is a serial one, we are limited to a total aggregate data rate equal to our single channel rate of 1 Mbps. In the future we hope to explore more powerful protocols that will allow fuller exploitation of the technology.

It is also important to point out that the 1 Mbps single channel data rate of the current system is by no means the limit. The maximum modulation bandwidth of the MQW devices at the current 800 μm pixel size is approximately 50 MHz, and higher rates would be possible with smaller pixels. Faster links would require more optical power, higher detector sensitivity, or more efficient modulation formats. We have demonstrated increased sensitivity with a coherent receiver and vector modulation to more efficiently use the available bandwidth. The current 1 Mbps, 3 meter link can be closed using 15 mW of laser light. But high reliability 300 mW, 980 nm laser diodes are now available, and more power can be expected in the future. In addition it may be possible to improve the photoresponse of the MQW devices by exploiting internal avalanche gain

By making full use of the technology and better protocols, single channel data rates of 100 Mbps and aggregate data rates of 1 Gbps seem possible.

6. ACKNOWLEDGEMENTS

We acknowledge the support of the Earth Science Technology Office and the AIST program.

REFERENCES

- [1] H. Scott Hinton, Tom J. Cloonan, Frederic B. McCormic, Jr., Anthony Lentine and Frank P. Tooley, "Free-Space Digital Optical Systems", Proceedings of the IEEE, Vol. 82, No. 11, 1632-1649, (1994)
- [2] David T. Neilson, "Tolerance of optical interconnections to misalignment", Appl. Opt., 38, pp. 2282-2290, (1999)
- [3] G. Charmaine Gilbreath, W. S. Rabinovich, Rita Mahon, D.S. Katzer, K. Ikossi-Anastasiou, Michael R. Corson, John F. Kline, Joshua Resnick, H. C. Merk, Michael J. Vilcheck, "Modulating retroreflector architecture using multiple quantum wells for free space optical communications", Proc. SPIE Vol. 3491, p. 581-586, December 1998.
- [4] D. S. Katzer, W. S. Rabinovich, K. Ikossi-Anastasiou, and G. C. Gilbreath, "Optimization of buffer layers for InGaAs/AlGaAs PIN optical modulators grown on GaAs substrates by molecular beam epitaxy", J. Vac. Sci. B 18, 1609-1613 (2000).



Peter G. Goetz (S'93-M'98) received the B.S. degree in electrical engineering from the University of Maryland, College Park in 1988. He received the M.S.E. and Ph.D. degrees in electrical engineering (solid state) from the University of Michigan, Ann Arbor, in 1996 and 1998, respectively. Dr. Goetz was an instructor at the Naval Nuclear Power School, Orlando, FL, from 1988 to 1992. In 1999 he joined the Photonics Technology Branch at the Naval Research Laboratory, where he has worked in the fields of large-area, low-power multiple quantum well modulating retroreflectors for free space optical communication as well as high current photodiodes. Dr. Goetz is a member of the IEEE Microwave Theory and Techniques and IEEE Lasers and Electro-Optics Societies.



William S. Rabinovich was born in New York, NY, on November 28, 1961. He received the B.S. degree in physics from the State University of New York at Stony Brook in 1982 and the M.S. and Ph.D. degrees, also in physics, from Brown University, Providence, RI, in 1984 and 1987, respectively. In 1987 he became a National Research Council Postdoctoral Associate at the Naval Research Laboratory (NRL) and in 1989 he became a research physicist with the Optical Science Division of NRL. His work at NRL has focused on the optical properties of quantum confined semiconductor materials. This work has included the development of multiple quantum well based spatial light modulators, nonlinear properties of intersubband transitions in quantum wells and large area multiple quantum well modulators for free space optical communications. He is the co-PI of the Quantum Well Modulating Retro-reflector program at NRL. In 2000 Dr. Rabinovich became head of the Photonic Materials and Devices Section of the Optical Science Division at NRL.



Rita Mahon received the B.Sc. and the Ph.D. degrees in Physics from Imperial College at the University of London in 1970 and 1973, respectively. She did postdoctoral research at York University in Toronto followed by a research associate position in Plasma Physics at the University of Maryland College Park. She works in the Photonics Technology branch of the Optical Science Division at the Naval Research Laboratory under contract with Jaycor.

Timothy J. Meehan received the B.S. degree in electrical engineering from the University of Maryland in 1996. He received the M.S. degree in electrical engineering from the

Johns Hopkins University in 2000. He has been at the Naval Research Laboratory since 1993, where his research focus is digital signal processing.

D. Scott Katzer (S'85—M'89) was born in Trenton, MI, in 1961. He received the B.A. degree in physics from the University of Chicago, Chicago, IL, in 1983, and the Ph.D. degree in solid-state electronics from the University of Cincinnati, Cincinnati, OH, in 1988. His dissertation topic was overlapping-gate GaAs CCD imagers. In 1989, he joined the Naval Research Laboratory, Washington, DC, as an Office of Naval Technology Postdoctoral Fellow. His research included GaAs *nipi* superlattice devices and optimization of interfaces in heterostructures grown by molecular beam epitaxy (MBE). Since 1991, he has been an Electronics Engineer in the High Frequency Devices and Materials Section of the Microwave Technology Branch at the NRL. His present research interests include the MBE growth of nitrogen- and arsenic-based III-V compounds, and the electronic and optoelectronic properties of novel III-V compound devices.

Steven C. Binari received the B.S. degree in physics from the College of William and Mary, Williamsburg, VA, in 1979 and the Master of Engineering Physics degree from the University of Virginia, Charlottesville, in 1980. In 1981, he joined the Naval Research Laboratory, Washington, DC. He has worked on a wide range of semiconductor materials and devices, focusing on GaN-based electronic devices for the last few years.



Eric E. Funk received a Ph. D. and M.S. in Electrical Engineering from the University of Maryland in 1995 and 1991 respectively, and a B.S. in Physics from Rensselaer Polytechnic Institute in 1988. Since 2000, he has been conducting research at the Naval Research Laboratory (NRL),

Washington, DC. At NRL his research is in the microwave photonics field. He was previously a Senior RF Design Engineer with EER Systems, Chantilly VA, a Research Associate at the University of Maryland, College Park, MD, and a Postdoctoral Fellow at the Army Research Laboratory, Adelphi, MD.

Lee Swingen received the B.S. degree in electrical engineering from the University of Wisconsin-Madison in 2001. He is a contractor with SFA, Inc. and has been working at the Naval Research Laboratory since 2001.



G. Charmaine Gilbreath received the B.S. in Physics from the Georgia Institute of Technology in 1982. She received her M.S.E. and Ph.D. in Engineering Science with an emphasis in optical communications from the Johns Hopkins University in Baltimore, MD in 1986 and 1989, respectively. Dr. Gilbreath has been with the NRL since 1982. The focus

of her work has been nonlinear optics, space-based optical communications, and satellite laser ranging for the DOD. She is presently the co-PI for NRL's MQW modulating retro-reflector programs. Dr. Gilbreath also works with the NRL/USNO team at the Naval Prototype Optical Interferometer in Flagstaff, AZ.

John Rende received the B.S. degree from CCNY in 1955. He received the M.S. in electrical engineering and the M.S. in Computer Science from the Johns Hopkins University in 1980 and 1983, respectively. He worked at the Naval Observatory from 1955 to 1962, and has been at NASA Goddard Space Flight Center since 1963. He was the Command system designer for the first shuttle, CDH lead for TERRA, and CDH lead for NPP.

Eugene Waluschka is with NASA Goddard Spaceflight Center. No biographical information is available at this time.

Gary Lepore is with NASA Goddard Spaceflight Center. No biographical information is available at this time.

Anthony Phan is with NASA Goddard Spaceflight Center. No biographical information is available at this time.